

AMERISTRUT[™]

Framing Channel
CATALOG

Schaeffer Industries

Schaeffer Industries was founded in 1979 by George Schaeffer and has been continuously active in the steel service center business and related steel manufacturing operations since 1981. Over the last three decades Schaeffer Industries has expanded far beyond its initial focus as a steel service center. Today, in addition to its steel service center operations, Schaeffer Industries has also become a recognized producer and distributor of high quality structural steel pipes and tubes and rollformed profiles.



Along with the *AMERISTRAUT™* product line, Schaeffer Industries through its rollforming division, American Rollforming and Manufacturing, provides thousands of tons annually of intermediate and heavy gauge rollformed profiles to the construction, traffic, storage, and agricultural markets.

With strategic manufacturing and distribution locations in northern and southern California, Utah, and Texas (open 2010), Schaeffer Industries is well positioned to serve our valued customers.

The ownership and staff of Schaeffer Industries look forward to supplying all of your future framing channel requirements.



TABLE OF CONTENTS

Overview

Process and Materials 1

Finishes 2

Profiles 3

Punching Options 4

Specifications

A-12 5

A-14 6

C-12 7

C-14 8

M-12 9

B-14 10

D-12 11

E-12 12

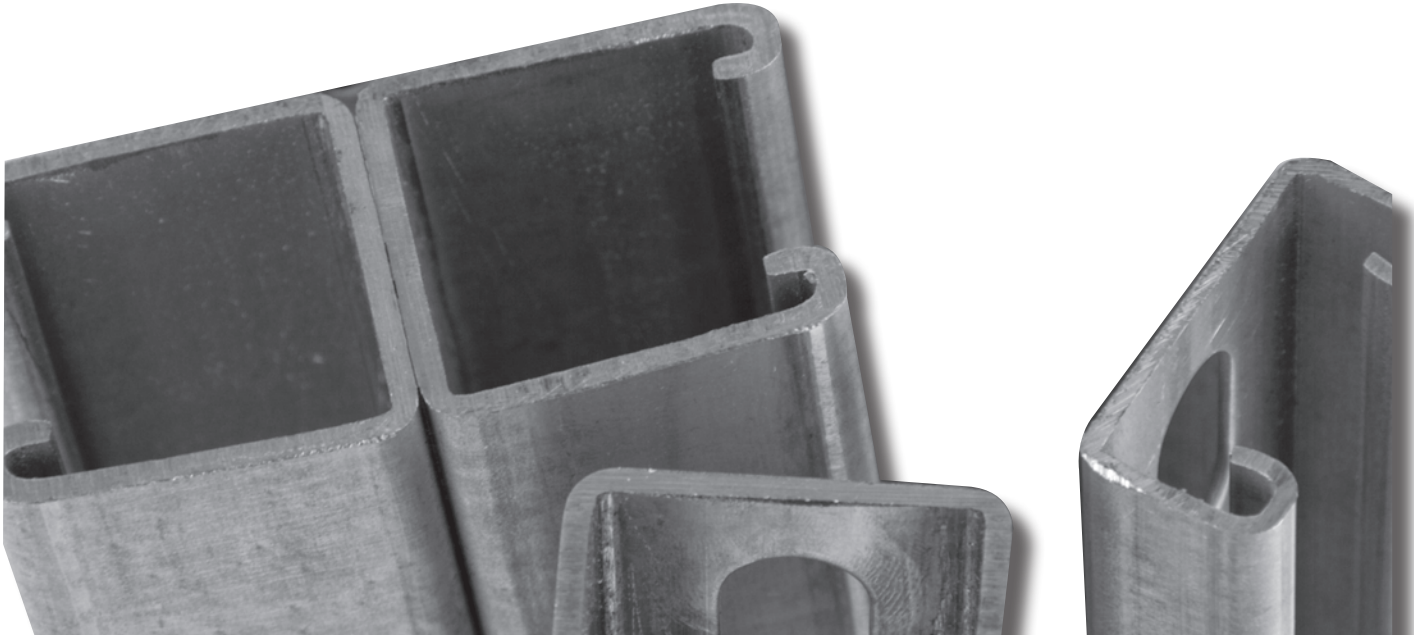

Manufacturing Process

A framing channel (strut) is manufactured through a process known as “rollforming.” Rollforming is the continuous transformation of flat steel strips (slit coils) into a final profile with the absence of heat. The machine that this process takes place upon is commonly referred to as a rollformer. Rollformers have numerous stands or positions on which specially designed tool steel rolls (roller dies) are placed. The roller dies vary from stand to stand and progressively shape the incoming flat steel strip into the final desired profile. Production of struts requires a rollformer with 14-16 positions (stands). The finished profile passes through a mechanical press containing a “cut-off die” which cuts the strut into 10’ and 20’ lengths. These lengths of strut are then inspected for quality prior to being packaged into 500’ bundles for shipment to our customers.

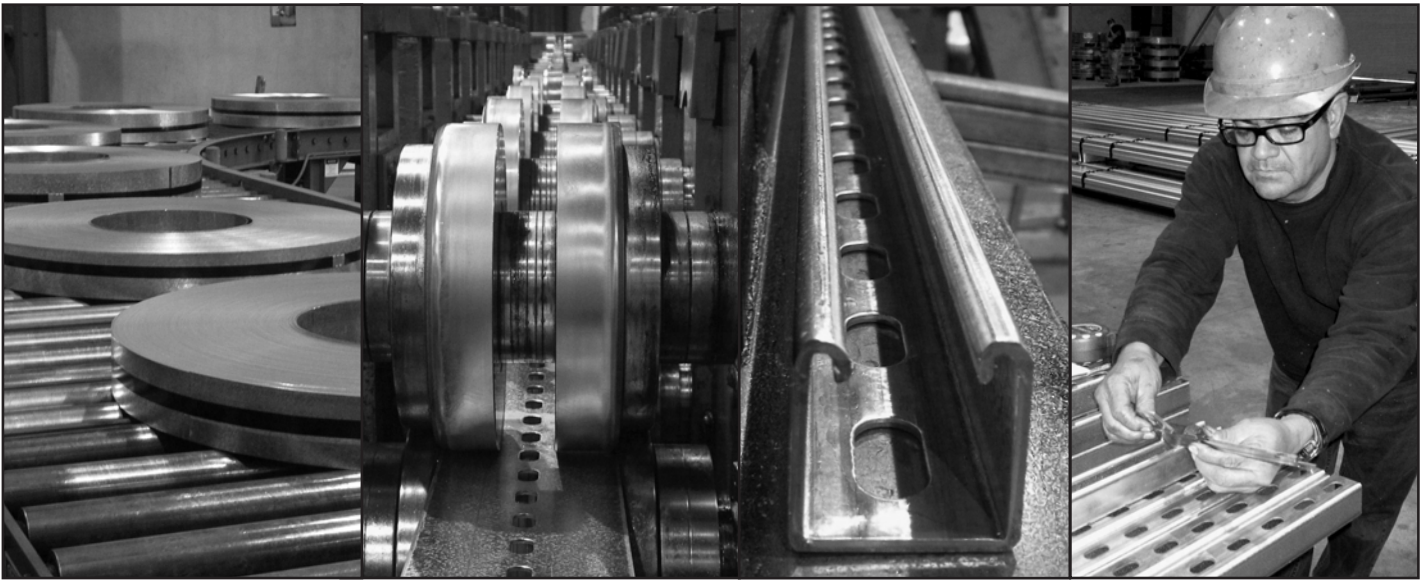

Materials

AMERISTRUT™ produces its Framing Channel (Strut) profiles from the following materials:

Carbon Steel:

Structural grade, steel sheet coil that has been melted and rolled at the steel mill to conform to ASTM A1011 SS Grade 33 (Hot Rolled) and ASTM A653 SS Grade 33 (Galvanized). These ASTM specifications require the mechanical properties to be a minimum of 33 ksi yield and 52 ksi tensile. Additionally, the mechanical properties of the incoming steel are further increased in the actual rollforming process. This is sometimes referred to as “work hardening.”

Stainless Steel:

Chromium–nickel austenitic steel sheet coil which has been melted, rolled, and annealed at the steel mill to conform to ASTM A-240 Type 304. Generally, stainless steel has a higher yield and tensile than carbon steel produced to a Grade 33. The mechanical properties of the incoming steel (stainless) tend not to increase as much as carbon steel in the rollforming process. Strut produced from stainless steel offers superior protection in harsh and corrosive environments.

Finishes

AMERISTRUT[™] offers its Framing Channel (Strut) profiles with the following surface finishes.

Plain "PL" (bare/uncoated):

Plain strut does not have any protective coating other than the residual mill oil and rolling lubricant that is applied in the rollforming process. Using bare strut in any application where it may be exposed to corrosion is not recommended.

Pre-Galvanized "PG":

Pre-Galvanized, also known as Hot Dipped Mill Galvanized or Mill Galvanized, is produced at the steel mills. Coils of carbon steel weighing up to 40 tons are unwound and passed (continuously) through a vessel containing molten zinc. This vessel is commonly referred to as a "Galvanizing Pot or Zinc Pot." The molten zinc alloys itself to the base metal (carbon steel) and is then cooled in a uniform manner and rewound back into a coil. The amount of zinc applied to the base metal used for manufacturing AmeriStrut meets all specifications of ASTM G90 which requires .9 oz minimum per sq foot of base metal. The nominal coating weight for G90 is 1.25 oz per sq foot. Prior to rewinding the pre-galvanized coil, a chromate coating (chem treat) and/or a light coating of rolling oil may be applied to prevent oxidation.

AMERISTRUT[™] **Green Painted "GN":**

Plain strut is thoroughly cleaned to remove all residual mill oils and rolling lubricants. The cleaned strut is then pre-treated with a phosphoric coating for additional corrosion resistance and improved paint adherence. From here a high grade of polyester powder paint is electro-statically applied. The strut is then placed on an overhead conveyor and is cycled through a curing oven for twenty minutes at 400°. Upon completion of this process the paint is chemically bonded to the base steel.*

If you require finishes or coatings other than what is shown, please inquire.

*AmeriStrut reserves the right to substitute alternate paint systems which will be of equal or superior quality to the system described above.

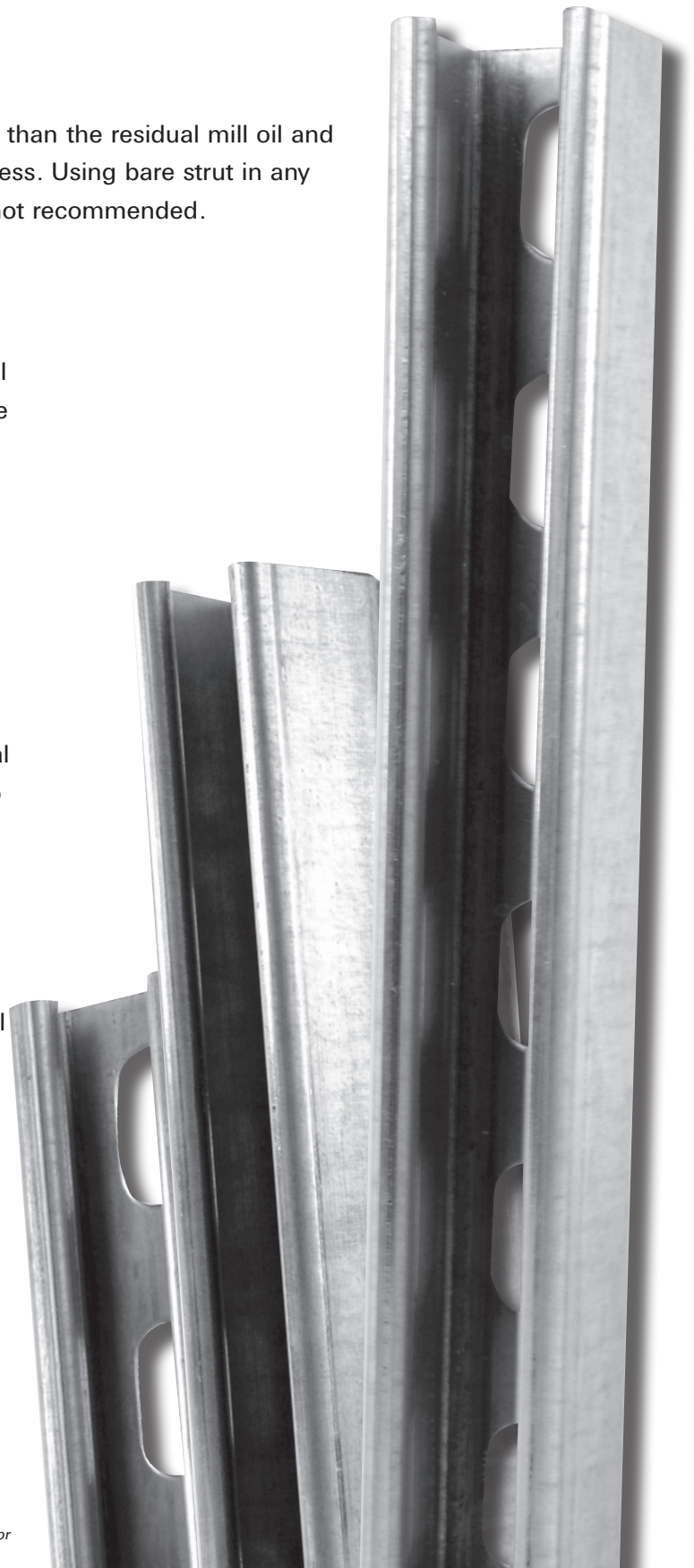

Profiles

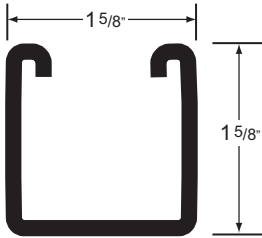

A-12 Channel

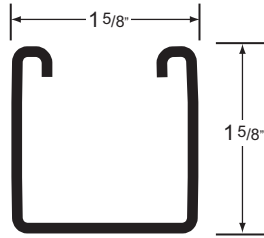

A-14 Channel

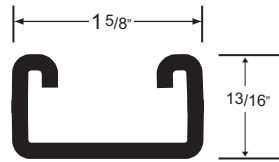

C-12 Channel

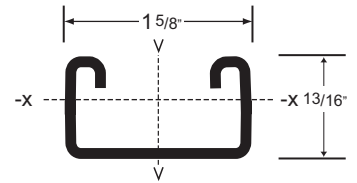

C-14 Channel

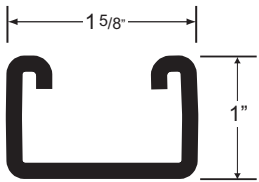

M-12 Channel

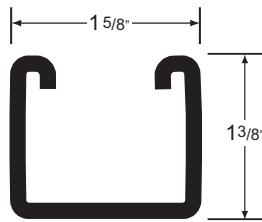

B-12 Channel

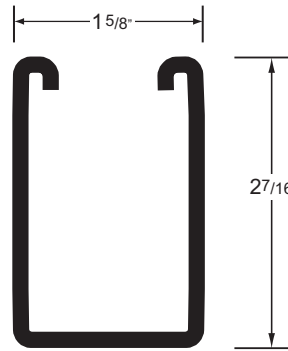

D-12 Channel

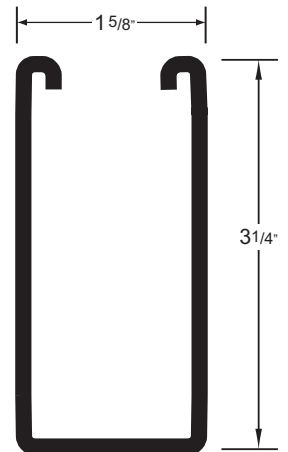

E-12 Channel

Punching Options

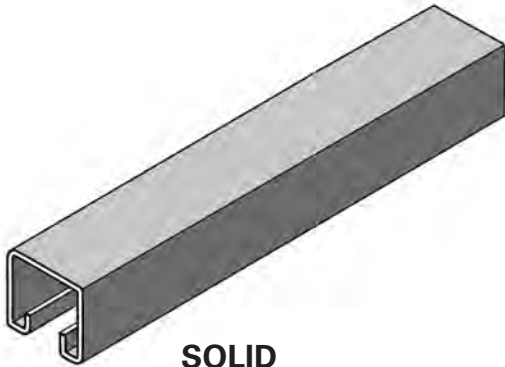

SOLID

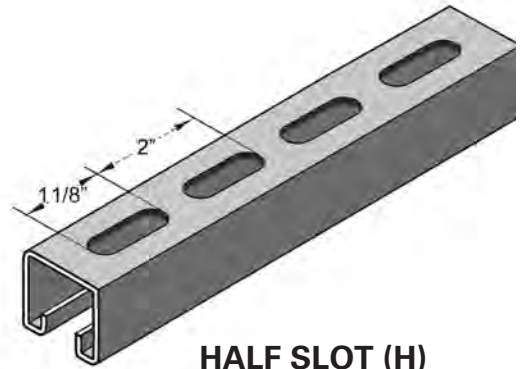

HALF SLOT (H)

1-1/8" x 9/16" slots punched on 2" centers

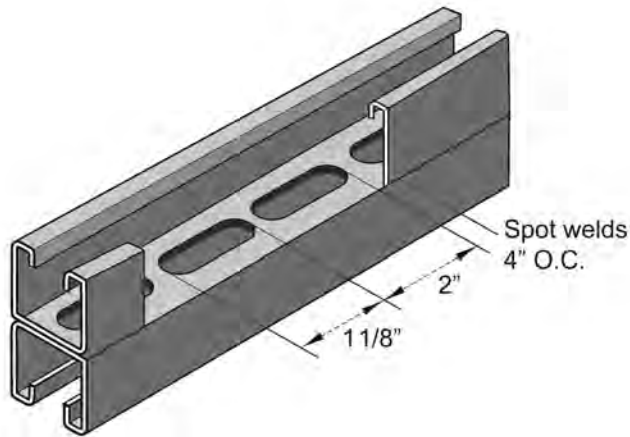

WELDED HALF SLOT (WH)

Back to back channel with standard half-slots

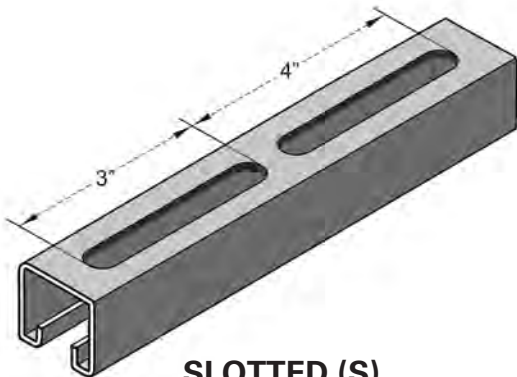

SLOTTED (S)

3" x 7/16" slots punched on 4" centers

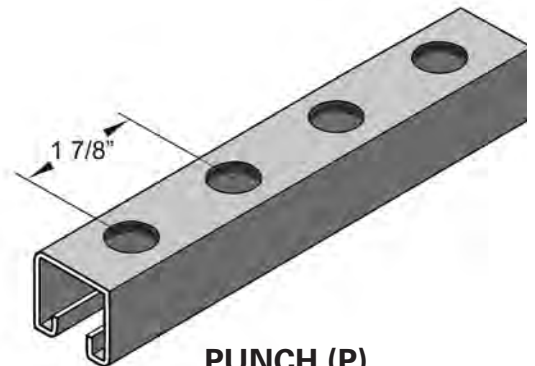

PUNCH (P)

9/16" holes punched on 1-7/8" centers

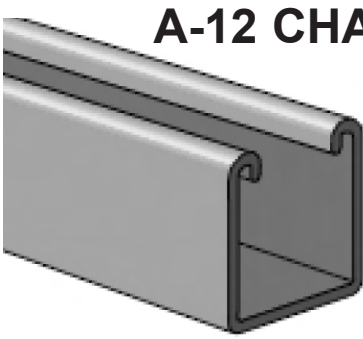

A-12 CHANNEL

Metal thickness is 12 Ga. (.105")

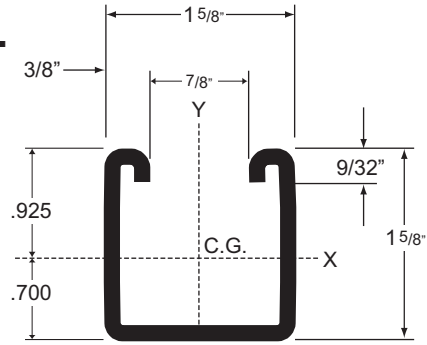

A-12

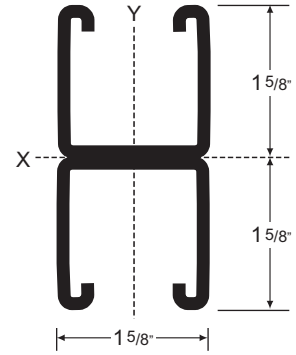

A-12A

Elements of Section

Channel Catalog Number	Weight lbs./ft.	Area of Section Sq. In.	AXIS X-X			AXIS Y-Y		
			I(in. ⁴)	S(in. ³)	R(in.)	I(in. ⁴)	S(in. ³)	R(in.)
A-12	1.89	.583	.188	.203	.581	.257	.316	.680
A-12A	3.78	1.166	.920	.566	.910	.514	.632	.680

I = Moment of inertia

S = Section modulus

R = Radius of gyration

Beam and Column Loads Data

Channel Catalog Number	Beam Span or Unbraced Column Height	Uniform Load at Stress of 25,000 PSI (lbs.)	Deflection at Stress of 25,000 PSI (in.)	Uniform Load (lbs.) When Maximum Deflection = $\frac{\text{SPAN}}{240}$	Maximum Allowable Load of Column (lbs.)
A-12	18"	2213	.031	2213	11300
	24"	1680	.055	1680	9700
	30"	1340	.086	1340	8850
	36"	1125	.125	1125	8600
	42"	950	.168	950	7550
	48"	855	.225	757	6720
	60"	690	.356	484	5800
	72"	555	.594	336	4970
	84"	490	.693	247	4250
	96"	433	.915	189	3500
	120"	335	1.382	121	2100
A-12A	18"	6530	.018	6530	24340
	24"	4895	.033	4895	21800
	30"	3800	.050	3800	21500
	36"	3100	.070	3100	21000
	42"	2700	.097	2700	20600
	48"	2300	.124	2300	19900
	60"	1930	.203	1930	17950
	72"	1560	.284	1560	15940
	84"	1360	.393	1210	14750
	96"	1200	.438	926	12650
	120"	953	.680	593	8000

Beam loads: Loads listed are uniformly distributed, for loads concentrated at center of span multiply uniform load at table by .5 and multiply the deflection by .8. When deflection is not a factor use stress of 25,000 PSI. When deflection is a factor use deflection of **SPAN/240**.

All weights and dimensions shown are subject to commercial tolerances.

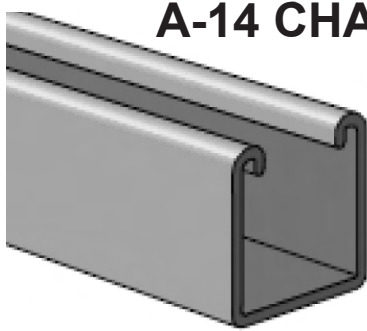

A-14 CHANNEL

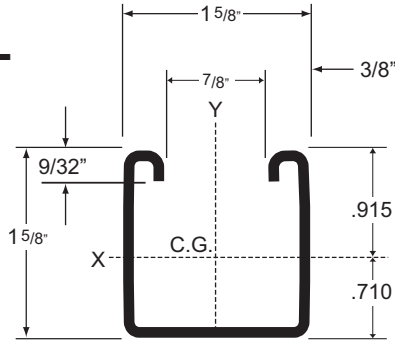

A-14

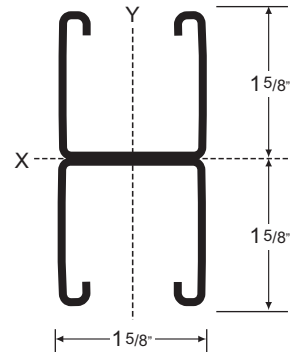

A-14A

Elements of Section

Channel Catalog Number	Weight lbs./ft.	Area of Section Sq. In.	AXIS X-X			AXIS Y-Y		
			I(in. ⁴)	S(in. ³)	R(in.)	I(in. ⁴)	S(in. ³)	R(in.)
A-14	1.35	.398	.142	.155	.597	.177	.215	.655
A-14A	2.70	.796	.685	.421	.927	.354	.430	.655

I = Moment of inertia

S = Section modulus

R = Radius of gyration

Beam and Column Loads Data

Channel Catalog Number	Beam Span or Unbraced Column Height	Uniform Load at Stress of 25,000 PSI (lbs.)	Deflection at Stress of 25,000 PSI (in.)	Uniform Load (lbs.) When Maximum Deflection = $\frac{\text{SPAN}}{240}$	Maximum Allowable Load of Column (lbs.)
A-14	18"	1850	.034	1850	7500
	24"	1360	.059	1360	6790
	30"	1050	.089	1050	6350
	36"	900	.133	900	6000
	42"	760	.178	760	5400
	48"	660	.230	572	4750
	60"	535	.365	366	4120
	72"	445	.525	254	3320
	84"	375	.702	186	2800
	96"	333	.931	143	2250
A-14A	120"	260	1.420	91	1520
	18"	5000	.019	5000	16500
	24"	3700	.033	3700	15000
	30"	2900	.051	2900	14250
	36"	2400	.073	2400	13950
	42"	2100	.102	2100	13500
	48"	1800	.130	1800	13100
	60"	1500	.212	1500	12000
	72"	1220	.298	1220	10950
	84"	1050	.407	900	9600
	96"	900	.522	689	7550
	120"	725	.849	441	4000

Beam loads: Loads listed are uniformly distributed, for loads concentrated at center of span multiply uniform load at table by .5 and multiply the deflection by .8. When deflection is not a factor use stress of 25,000 PSI. When deflection is a factor use deflection of $\frac{\text{SPAN}}{240}$.

All weights and dimensions shown are subject to commercial tolerances.

C-12 CHANNEL

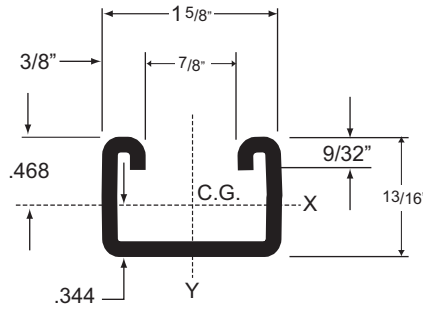
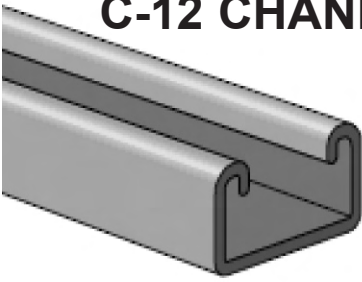

C-12

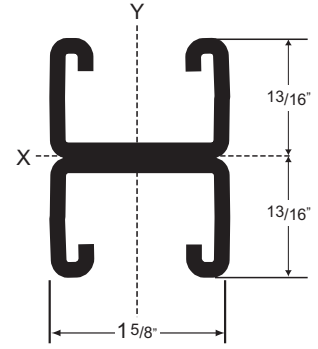

C-12A

Metal thickness is 12 Ga. (.105")

Elements of Section

Channel Catalog Number	Weight lbs./ft.	Area of Section Sq. In.	AXIS X-X			AXIS Y-Y		
			I(in. ⁴)	S(in. ³)	R(in.)	I(in. ⁴)	S(in. ³)	R(in.)
C-12	1.27	.375	.032	.066	.291	.126	.155	.577
C-12A	2.54	.750	.148	.182	.442	.252	.311	.577

I = Moment of inertia

S = Section modulus

R = Radius of gyration

Beam and Column Loads Data

Channel Catalog Number	Beam Span or Unbraced Column Height	Uniform Load at Stress of 25,000 PSI (lbs.)	Deflection at Stress of 25,000 PSI (in.)	Uniform Load (lbs.) When Maximum Deflection = $\frac{SPAN}{240}$	Maximum Allowable Load of Column (lbs.)
C-12	18"	760	.058	700	6700
	24"	555	.103	506	6250
	30"	450	.150	365	5300
	36"	370	.230	240	4100
	42"	320	.300	185	3950
	48"	275	.409	136	2720
	60"	223	.644	86	1950
	72"	185	.925	58	910
	84"	157	1.220	43	665
	96"	137	1.649	34	
	120"	109	2.574	20	
C-12A	18"	1270	.026	1270	15890
	24"	1270	.051	1270	15700
	30"	1215	.090	1130	14720
	36"	1012	.136	1013	13660
	42"	870	.180	840	13050
	48"	759	.245	624	11530
	60"	607	.381	399	9450
	72"	506	.548	278	6780
	84"	432	.743	179	4850
	96"	380	.971	156	3750
	120"	302	1.517	99	2450

Beam loads: Loads listed are uniformly distributed, for loads concentrated at center of span multiply uniform load at table by .5 and multiply the deflection by .8. When deflection is not a factor use stress of 25,000 PSI. When deflection is a factor use deflection of $SPAN/240$.

All weights and dimensions shown are subject to commercial tolerances.

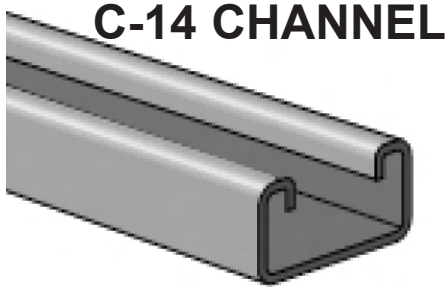

C-14 CHANNEL

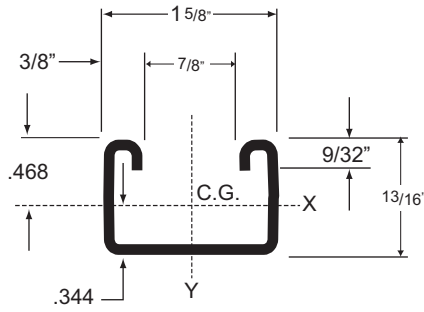

C-14

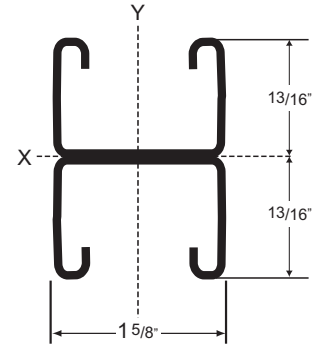

C-14A

Metal thickness is 14 Ga. (.075")

Elements of Section

Channel Catalog Number	Weight lbs./ft.	Area of Section Sq. In.	AXIS X-X			AXIS Y-Y		
			I(in. ⁴)	S(in. ³)	R(in.)	I(in. ⁴)	S(in. ³)	R(in.)
C-14	1.00	.275	.028	.060	.319	.116	.142	.649
C-14A	2.00	.550	.121	.149	.469	.232	.284	.649

I = Moment of inertia

S = Section modulus

R = Radius of gyration

Beam and Column Loads Data

Channel Catalog Number	Beam Span or Unbraced Column Height	Uniform Load at Stress of 25,000 PSI (lbs.)	Deflection at Stress of 25,000 PSI (in.)	Uniform Load (lbs.) When Maximum Deflection = $\frac{\text{SPAN}}{240}$	Maximum Allowable Load of Column (lbs.)
C-14	18" 6	25	.058	625	4600
	24"	468	.103	451	4150
	30"	380	.164	289	3900
	36"	310	.232	200	3580
	42"	270	.320	147	3300
	48"	235	.417	113	2900
	60"	190	.658	72	2550
	72"	155	.928	50	750
	84"	130	1.235	36	560
	96"				
	120"				
C-14A	18"	1680	.036	1680	9600
	24"	1220	.062	1220	9400
	30"	985	.098	985	8950
	36"	820	.142	820	8480
	42"	710	.195	636	8100
	48"	620	.254	487	7600
	60"	495	.396	312	7000
	72"	400	.554	217	5800
	84"	350	.769	159	3950
	96"				
	120"				

Beam loads: Loads listed are uniformly distributed, for loads concentrated at center of span multiply uniform load at table by .5 and multiply the deflection by .8. When deflection is not a factor use stress of 25,000 PSI. When deflection is a factor use deflection of $\frac{\text{SPAN}}{240}$.

All weights and dimensions shown are subject to commercial tolerances.

M-12 CHANNEL

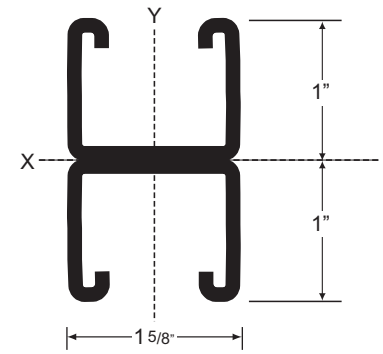
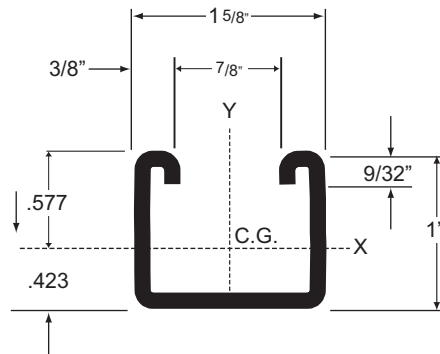
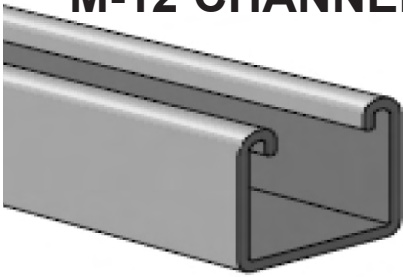

Metal thickness is 12 Ga. (.105")

M-12

M-12A

Elements of Section

Channel Catalog Number	Weight lbs./ft.	Area of Section Sq. In.	AXIS X-X			AXIS Y-Y		
			I(in. ⁴)	S(in. ³)	R(in.)	I(in. ⁴)	S(in. ³)	R(in.)
M-12	1.41	.418	.066	.099	.364	.157	.193	.594
M-12A	2.83	.836	.306	.268	.552	.314	.386	.604

I = Moment of inertia

S = Section modulus

R = Radius of gyration

Beam and Column Loads Data

Channel Catalog Number	Beam Span or Unbraced Column Height	Uniform Load at Stress of 25,000 PSI (lbs.)	Deflection at Stress of 25,000 PSI (in.)	Uniform Load (lbs.) When Maximum Deflection = $\frac{SPAN}{240}$	Maximum Allowable Load of Column (lbs.)
M-12	18"	1095	.051	1054	7300
	24"	815	.088	780	6870
	30"	650	.145	595	6000
	36"	535	.198	446	5150
	42"	463	.275	359	4740
	48"	402	.352	273	3640
	60"	327	.550	174	2890
	72"	269	.792	120	1940
	84"	231	1.079	88	1540
	96"	199	1.409	68	775
	120"	160	2.202	42	
M-12A	18"	2480	.024	2480	16500
	24"	2075	.046	2075	16200
	30"	1785	.080	1725	15400
	36"	1480	.119	1480	14670
	42"	1290	.159	1265	14100
	48"	1115	.214	1020	13030
	60"	895	.334	750	11340
	72"	750	.481	552	8840
	84"	640	.653	392	7270
	96"	560	.847	313	5920
	120"	447	1.324	200	3710

Beam loads: Loads listed are uniformly distributed, for loads concentrated at center of span multiply uniform load at table by .5 and multiply the deflection by .8. When deflection is not a factor use stress of 25,000 PSI. When deflection is a factor use deflection of **SPAN/240**.

All weights and dimensions shown are subject to commercial tolerances.

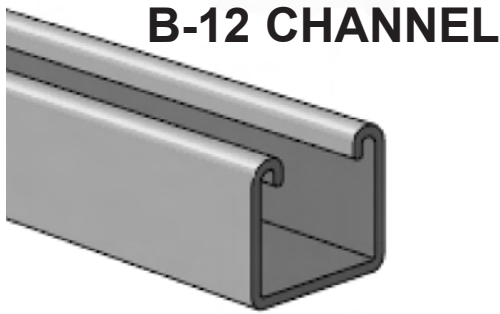

B-12 CHANNEL

Metal thickness is 12 Ga. (.105")

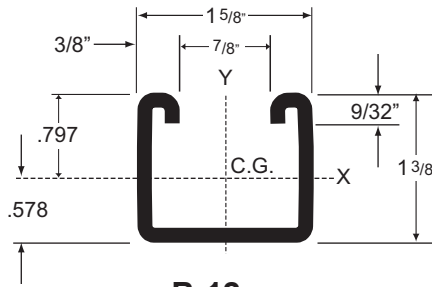

B-12

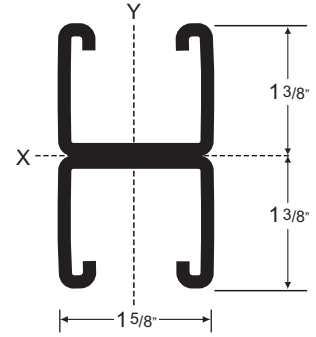

B-12A

Elements of Section

Channel Catalog Number	Weight lbs./ft.	Area of Section Sq. In.	AXIS X-X			AXIS Y-Y		
			I(in. ⁴)	S(in. ³)	R(in.)	I(in. ⁴)	S(in. ³)	R(in.)
B-12	1.704	.500	.134	.168	.517	.219	.269	.662
B-12A	3.408	1.000	.602	.438	.775	.438	.538	.662

I = Moment of inertia

S = Section modulus

R = Radius of gyration

Beam and Column Loads Data

Channel Catalog Number	Beam Span or Unbraced Column Height	Uniform Load at Stress of 25,000 PSI (lbs.)	Deflection at Stress of 25,000 PSI (in.)	Uniform Load (lbs.) When Maximum Deflection = $\frac{SPAN}{240}$	Maximum Allowable Load of Column (lbs.)
B-12	18"	1766	.035	1766	8200
	24"	1330	.062	1330	7960
	30"	1050	.095	1050	7400
	36"	858	.134	858	7250
	42"	748	.185	705	6280
	48"	650	.241	539	5490
	60"	530	.383	345	4820
	72"	435	.544	240	4080
	84"	378	.750	176	3320
	96"	315	.934	135	2860
B-12A	120"	260	1.500	86	2100
	18"	4900	.021	4900	17650
	24"	3650	.037	3650	17200
	30"	2900	.058	2900	16800
	36"	2400	.083	2400	16450
	42"	2120	.117	2120	16000
	48"	1820	.150	1820	15600
	60"	1450	.233	1450	15050
	72"	1230	.342	1077	12900
	84"	1050	.464	792	12250
96"	910	.600	606	10380	
120"	730	.940	388	6200	

Beam loads: Loads listed are uniformly distributed, for loads concentrated at center of span multiply uniform load at table by .5 and multiply the deflection by .8. When deflection is not a factor use stress of 25,000 PSI. When deflection is a factor use deflection of $\frac{SPAN}{240}$.

All weights and dimensions shown are subject to commercial tolerances.

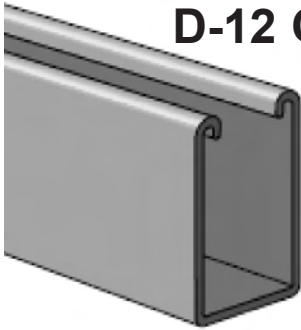

D-12 CHANNEL

Metal thickness is 12 Ga. (.105")

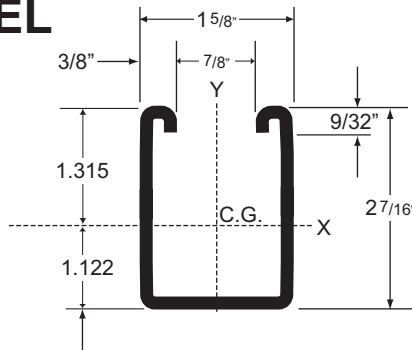

D-12

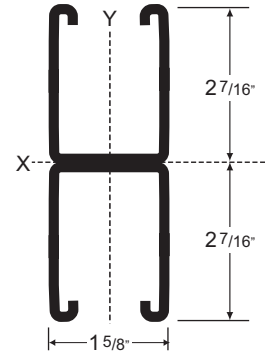

D-12A

Elements of Section

Channel Catalog Number	Weight lbs./ft.	Area of Section Sq. In.	AXIS X-X			AXIS Y-Y		
			I(in. ⁴)	S(in. ³)	R(in.)	I(in. ⁴)	S(in. ³)	R(in.)
D-12	2.47	.725	.520	.395	.847	.337	.415	.682
D-12A	4.94	1.450	2.865	1.175	1.405	.674	.830	.682

I = Moment of inertia

S = Section modulus

R = Radius of gyration

Beam and Column Loads Data

Channel Catalog Number	Beam Span or Unbraced Column Height	Uniform Load at Stress of 25,000 PSI (lbs.)	Deflection at Stress of 25,000 PSI (in.)	Uniform Load (lbs.) When Maximum Deflection = $\frac{\text{SPAN}}{240}$	Maximum Allowable Load of Column (lbs.)
D-12	18"	4400	.022	4400	10500
	24"	3280	.039	3280	9800
	30"	2650	.062	2650	9650
	36"	2180	.088	2180	9000
	42"	1880	.120	1880	8800
	48"	1620	.154	1620	8150
	60"	1320	.246	1320	6900
	72"	1100	.354	930	5850
	84"	930	.475	684	5000
	96"	820	.626	523	4450
	120"	645	.962	335	3200
D-12A	18"	13000	.012	13000	18500
	24"	9800	.021	9800	18450
	30"	7700	.032	7700	18380
	36"	6450	.047	6450	18300
	42"	5450	.063	5450	18200
	48"	4800	.083	4800	18100
	60"	3850	.130	3850	17900
	72"	3200	.187	3200	17550
	84"	2750	.255	2750	16650
	96"	2420	.335	2420	14800
	120"	1920	.519	1846	9000

Beam loads: Loads listed are uniformly distributed, for loads concentrated at center of span multiply uniform load at table by .5 and multiply the deflection by .8. When deflection is not a factor use stress of 25,000 PSI. When deflection is a factor use deflection of **SPAN/240**.

All weights and dimensions shown are subject to commercial tolerances.

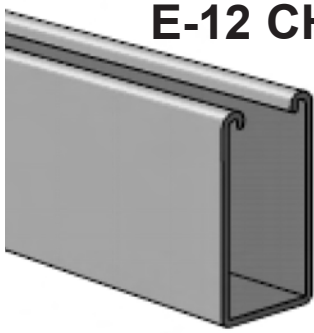

E-12 CHANNEL

Metal thickness is 12 Ga. (.105")

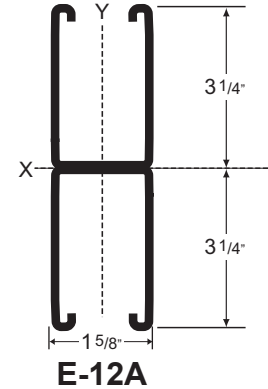
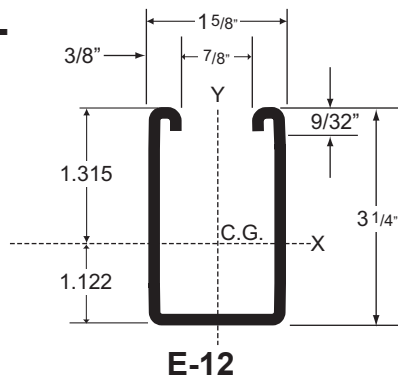

Elements of Section

Channel Catalog Number	Weight lbs./ft.	Area of Section Sq. In.	AXIS X-X			AXIS Y-Y		
			I(in. ⁴)	S(in. ³)	R(in.)	I(in. ⁴)	S(in. ³)	R(in.)
E-12	3.06	.898	1.111	.640	1.112	.438	.539	.698
E-12A	6.12	1.796	6.344	1.920	1.879	.876	1.078	.698

I = Moment of inertia

S = Section modulus

R = Radius of gyration

Beam and Column Loads Data

Channel Catalog Number	Beam Span or Unbraced Column Height	Uniform Load at Stress of 25,000 PSI (lbs.)	Deflection at Stress of 25,000 PSI (in.)	Uniform Load (lbs.) When Maximum Deflection = $\frac{SPAN}{240}$	Maximum Allowable Load of Column (lbs.)
E-12	36"	3700	.069	3700	10000
	48"	2800	.125	2800	8000
	60"	2150	.187	2150	7100
	72"	1750	.264	1750	6620
	84"	1500	.359	1461	5000
	96"	1350	.482	1118	4780
	120"	1100	.768	716	4400
	144"	880	1.062	497	
	168"	750	1.437	365	
	192"	650	1.859	279	
E-12A	240"	530	2.961	179	
	72"	5500	.145	5500	13000
	84"	4900	.205	4900	11200
	96"	4000	.250	4000	10000
	120"	3200	.391	3200	8800
	144"	2750	.581	2750	
	168"	2320	.778	2085	
	192"	2000	1.002	1597	
216"	1790	1.276	1261		
240"	1610	1.575	1022		

Beam loads: Loads listed are uniformly distributed, for loads concentrated at center of span multiply uniform load at table by .5 and multiply the deflection by .8. When deflection is not a factor use stress of 25,000 PSI. When deflection is a factor use deflection of **SPAN/240**.

All weights and dimensions shown are subject to commercial tolerances.

AMERISTRUT™

Schaeffer Industries

3030 Dulles Drive
Mira Loma, CA 91752

Tel (800) 748-4844
Fax (951) 681-1088

ameristrut.com

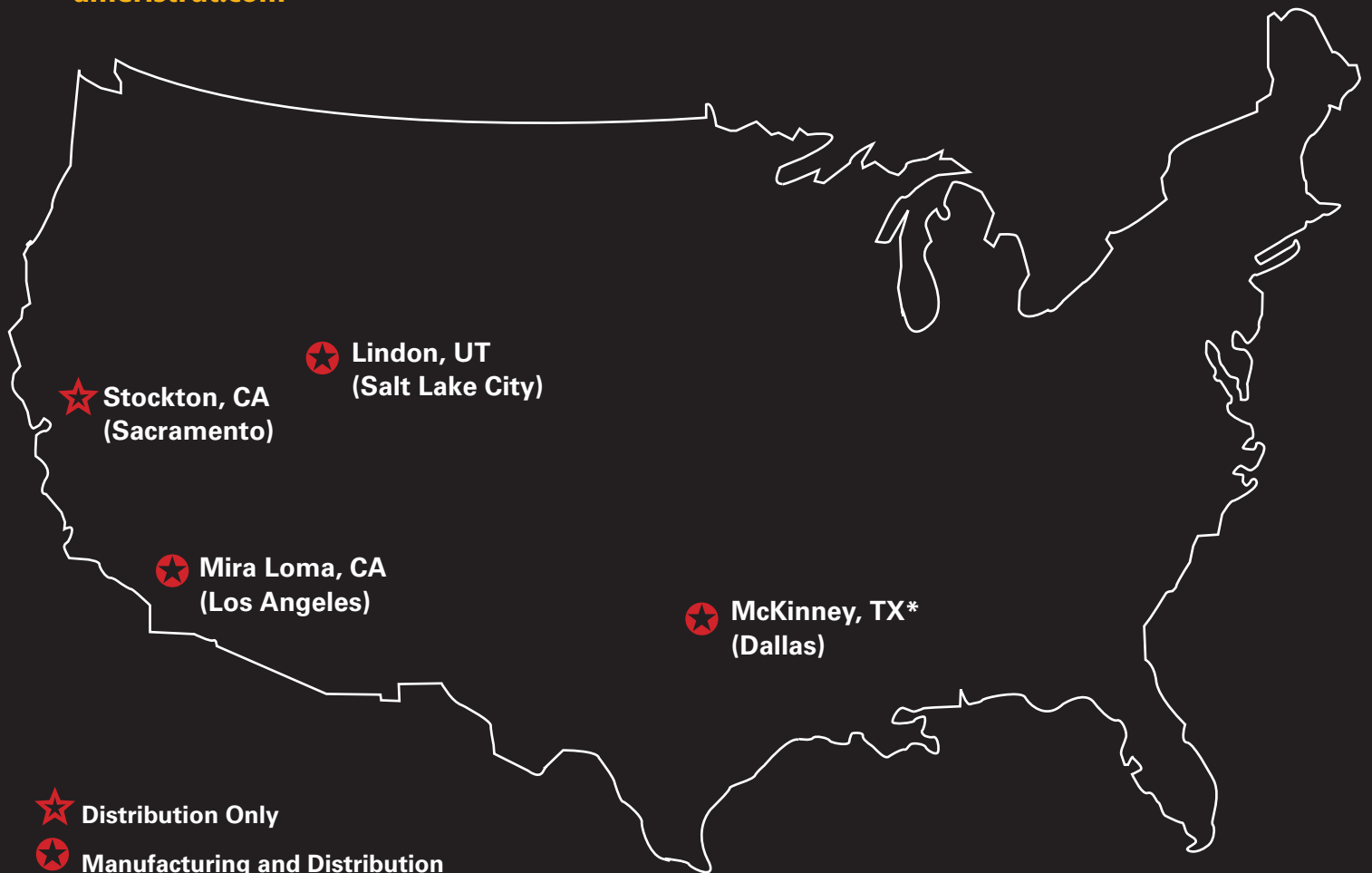

★ Stockton, CA
(Sacramento)

★ Lindon, UT
(Salt Lake City)

★ Mira Loma, CA
(Los Angeles)

★ McKinney, TX*
(Dallas)

★ Distribution Only

★ Manufacturing and Distribution

* Opening 2010